

RAILWAYS Range

Monoblock Reader

MOL81 1354

www.tagmaster.com

contact.fr@tagmaster.com

DESCRIPTION

The MOL81 is a short range transceiver specially designed for railway applications. An all-in-one device with integrated antenna, it will typically be installed on board rolling stock, mounted externally under the vehicle chassis or the boggie, in order to do on-the-fly reading of OMR radio-frequency identification beacons placed on the track between the rails. The data read from the beacons is sent to a control device (programmable controller or embedded calculator ...) over a balanced simplex serial link to ensure a localization function in real time or upon arriving at the terminal.

The MOL81 1354 sends the raw FM0-encoded data transparently through a unidirectional differential output RS422 Data Tx, no decoding, no software processing and no memorization of the identification code of the beacon, allowing the MOL81 1354 to be used in building a SIL system.

A dual frequency system, the MOL81 incorporates a 125kHz transmitter for remote powering of beacons and a 6.78MHz receiver for data coming from the beacons.

The transmitter can be activated by a request through a digital input.

The MOL81 1354 has a self-test for the 6.78MHz receiver that can be activated via an unidirectional differential input RS422 Data Rx. It also provides a digital output which indicates correct operation of the 125 kHz transmitter.

In addition a RS485 serial service link can be used for reader maintenance.



FUNCTIONAL DATA

The OMR201 beacon can be read by a MOL81, as shown in the picture opposite.

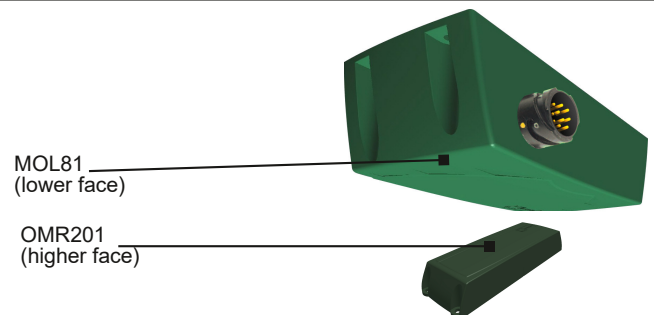

DIMENSIONS

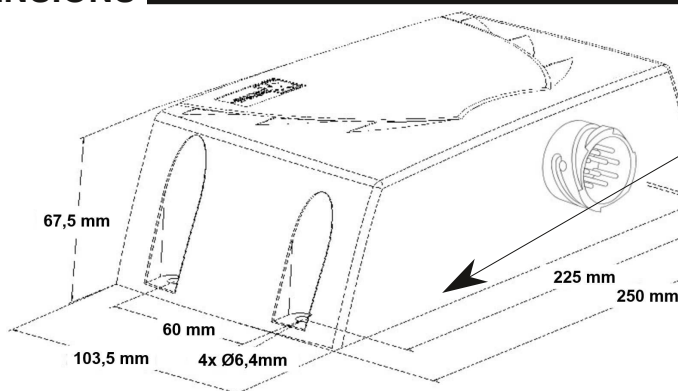

Marking :

Part number identification :
MOL81 1354

Serial number identification :
yywwxxxxx-nnn vvv
yy = year
ww=week
xxxxxx= factory order
nnn=serial number
vvv=revision index

TagMaster

LEARN FROM REALITY

PRINCIPLE OF OPERATION

The reader is designed to be powered with a SELV (Safety Extra Low Voltage) 24Vdc supply.

The 125kHz transmitter provides remote power to the beacon. It can be enabled and disabled with the digital input "Cde125kHz". When activated, a permanent control of the emission at 125kHz is performed by the reader. This information is sent directly to the "Pres125kHz" output, indicating the presence or absence of a correct 125kHz transmission.

The 6.78MHz receiver processes the identification signal sent by the beacon. After analog processing the signal is sent directly to the unidirectional differential output RS422 "Data-Tx".

A test pattern generated by the on-board calculator is injected via a RS422 link into the "Data-Rx" differential input, allowing testing of the entire reader receiver.

An RS485 serial link can be used for the maintenance of the reader.

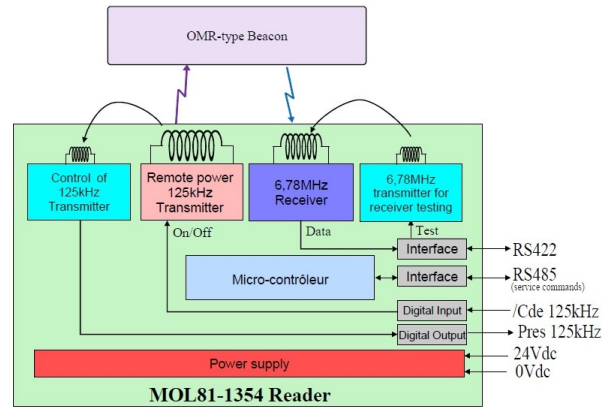

TECHNICAL SPECIFICATIONS

Radiofrequency communication with OMR-type beacon

	min	typ	max	unit
--	-----	-----	-----	------

Maximum length z for x=y=0 ⁽¹⁾			700	mm
Recommended range ^{(1) (2)} Δz	120		300	mm
Transmission zone length ^{(1) (2)}	1 000			mm
Emission carrier frequency		125		kHz
Reception carrier frequency		6.78		MHz
Quantity of data reads by MOL81 1354 @130km/h			170	bits
Reponse time (between a bit emitted by the beacon and sent for the Data-Tx serial link of the MOL81 1354 reader)			10	ms

⁽¹⁾ : With metallic environment as indicated page 6

⁽²⁾ : Position with respect to the beacon : maximum angular offset θx : +/-10°; θy : +/-10°; θz : +/-10°, and maximum shift Δymax =+/-200mm (+/-100mm recommended) (see page 6) - Δz is the distance between the two opposite faces of the reader and the beacon

Power supply

DC power supply at the connector (ripple included) : Upwr	21	24	30	V
Consumption @ 24V +/-10% ("Cde125kHz" active)		800	1 000	mA
Consumption @ 24V +/-10% ("Cde125kHz" inactive)		140	200	mA
Protection against reverse polarity	protected			-
Peak current at startup	2			A

Digital input "Cde125kHz"

High level input voltage V _{IH}	10		29	V
Low level input voltage V _{IL}			5	V
Sink current	2		50	mA
Protection against reverse polarity	protected			-

Digital output "Pres125kHz"

High level output voltage V _{OH}	15	21		V
@I _{OH} =10mA	10	15		V
Low level output voltage V _{OL}			0,5	V
Continuous output current I _{OH}			40	mA
Short circuit of the load	protected			-

TagMaster

LEARN FROM REALITY

TECHNICAL SPECIFICATIONS

	min	typ	max	unit
Insulation Groups				
N°1 : Power supply, Serial link, digital outputs				-
N°2 : Connector body, cable shield				-
Insulation voltage between each group	2			kVeff
Insulation resistance between each group @ 500Vdc	1			GΩ

Others Electrical service conditions

Interruption of voltage supply EN 50155 -STM-E-01-IndB	Class S1	-
Power supply fluctuation around Un=24Vdc : EN 50155 -STM-E-01-IndB	0,6 Un to 1,4 Un : Criterion A	-
Voltage supply decrease-increase: STM-E-01-IndB	24Vdc to 0Vdc - 0Vdc to 24Vdc during 1minute	-
Supply change over : EN 50155 -STM-E-01-IndB	Class C1 & Class C2	-

Environment

Operating temperature class Tx : EN 50155- STM-E-01-IndB (natural cooling)	-25		+70 ⁽³⁾	°C
Storage temperature	-40		+85	°C
Electromagnetic (EMC) : EN 50155 -STM-E-01-IndB	EN 50121-3-2 & EN 50121-4			-
Radiofrequency	EN 300330			-
Human exposure	EN 50364			-
Electrical safety	EN 60950			-
Shock and vibrations: mounting on bogie (EN 50155 -STM-E-01-IndB) or sleeper	EN 61373 & EN 50125-3			-
Fire / Smoke : EN 50155 - STM-S-001	EN 45545-2 : R23 HL2			-
Ingress protection rating EN 50155 -STM-E-01-IndB	EN 60529 : IP67 - IP69			-
Temperature cold test - dry heat test : EN 50155 -STM-E-01-IndB	EN 60068-2-1 & EN 60068-2-2			-
Temperature damp heat test : EN 50155 -STM-E-01-IndB- EN 60068-2-30	55°C insulation resistance >10MΩ			-
Humidity EN 50125-3 - EN 60068-2-78	95% insulation resistance >10MΩ			-
Altitude : EN 50155 -STM-E-01-IndB- EN 50125-1	1 200			m
Rapid temperature variations : EN 50155 -STM-E-01-IndB	EN 60068-2-14 : -25°C to +85°C			-
Low temperature storage test : EN 50155 -STM-E-01-IndB	EN 60068-2-1 : -40°C			-
Salt mist test : EN 50155 -STM-E-01-IndB	EN60068-2-11 : 500h			-
Burn-in test : EN 50155 (routine test)	16			h
RoHS European directive 2011/65/EU and REACH European directive n°1907/2006	Compliant			-
RED European directive 2014/53/UE	Compliant			-
⁽³⁾ : including the possible effects of altitude and solar radiation of 1120W/m ²				

Enclosure

Weight		2 500		g
Enclosure material	PA6 (Polyamide 6)			-
Coating	Polyurethane			-
Recommended tightening torque (4 screws)		5		N.m

RAMS features

MTBF according to IEC62380 railways (informative data)	mobile installation : 592 000 fixed installation : 1138 000	h
--	--	---

TagMaster

LEARN FROM REALITY

TECHNICAL SPECIFICATIONS

DataTx output bits time

The DataTx output bits from a beacon, is an FM0 signal format. The temporal distortion between the edges of the DataTx output RS422 signal sent over the serial link of the reader when receiving a beacon identification message is +/- 15% over the temperature range, compared to the theoretical FM0 bit time of 16us.

Likewise, the temporal distortion between the edges of the DataTx output RS422 signal sent over the serial link of the reader when receiving a self-test message coming from DataRx input is +/-15% over the temperature range, with respect to the bit time at the DataRx input.

Remark : The first bit of the DataRx message can reach a tolerance of +/-20% at the DataTx output.

Pres125kHz output behavior

The diagram below gives the time to get a valid information for 'Pres125kHz' output after power-up and, the activation and deactivation time of 'Pres125kHz' output.

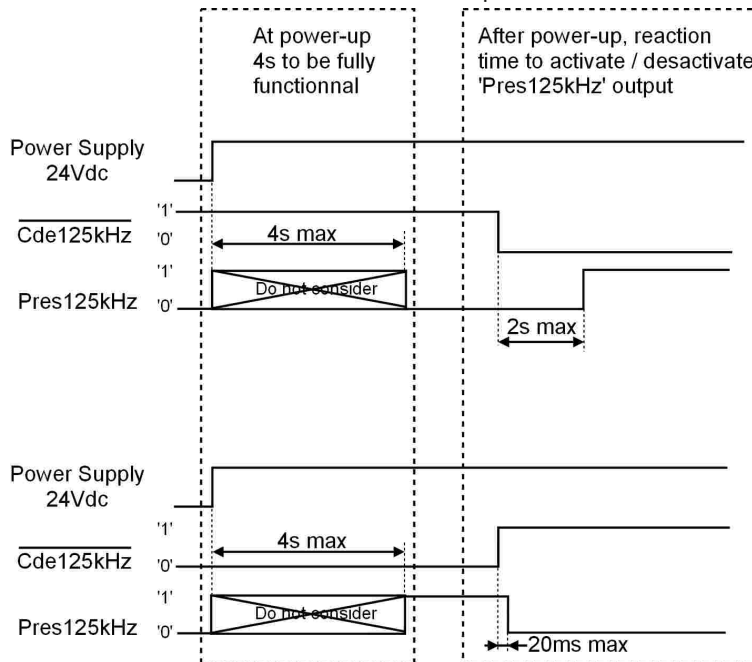

Receiver test behavior via Data Rx

The diagram below gives the waiting time after a power-up to perform a test of the receiver via Data Rx input and receive the data on Data Tx output.

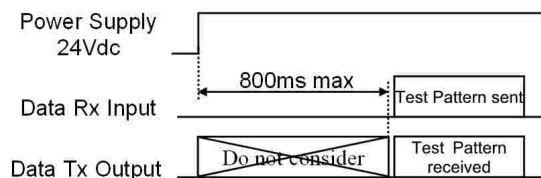

CONNECTING

□ Recommended cable:

- 10 wires:
 - Power supply : 2 wires
 - Input : 1 wire
 - Output : 1 wire
 - RS422 Data Tx (unidirectionnal) : 2 wires twisted pair, 120Ω line impedance ⁽⁴⁾
 - RS 422 Data RX (unidirectionnal) : 2 wires twisted pair, 120Ω line impedance ⁽⁴⁾
 - RS 485 Service Serial link : 2 wires twisted pair, 120Ω line impedance ⁽⁴⁾
- Cable shield; it must make full 360° contact with the metallic connector housing.
- Conductors connected by crimping, wire cross section : 0.5 to 1.5 mm² (depending of plug reference, see § accessories)
- Outer diameter of cable: 8 to 12.5 mm (depending of plug reference, see § accessories).
- Length: 200m max for serial link; length for power link depends on wire cross section (typically 50 to 150m max)

□ Connection:

Pin	MOL81 1354
A	Input : \overline{Cde} 125kHz (active low)
B	RS 422 output Data Tx-
C	Power supply : 24Vdc
D	RS 422 output Data Tx+
E	RS 422 input Data Rx+
F	RS 485 B (service commands)
G	RS 485 A (service commands)
H	RS 422 input Data Rx-
J	Common : 0Vdc
K	Output : Pres125kHz

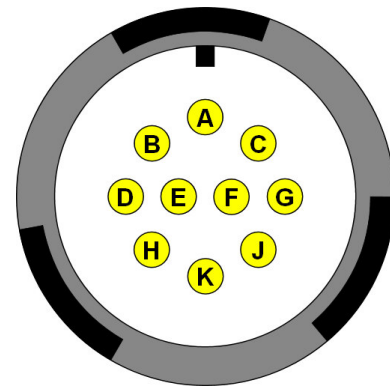

VGE1 type connector from Souraiu
Pin side view of the male receptacle
or wiring side view of the female plug

(4) :RS422 Tx - RS422 Rx and RS485 : line impedance matching done inside the device.

ACCESSORIES (to order separately)

- 10-pin female plug for Ø 8 to 12,5mm cable :
FFM SOU VGE1/10P for straight version and FFM C SOU VGE1/10P for elbow 90° version

TagMaster

LEARN FROM REALITY

MOUNTING SPECIFICATIONS

• Metallic environment for MOL81 1354 :

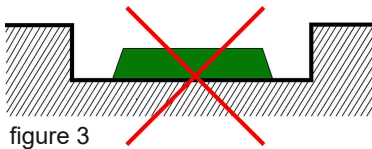
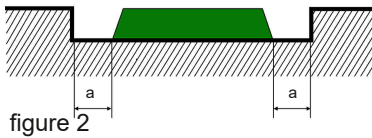
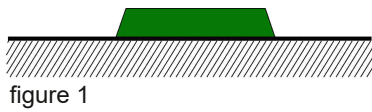

In order to guarantee correct range:

- The device must be mounted directly onto a metallic plate (figure 1), which extends at least $a=10\text{cm}$ beyond the base in both directions.

- Beyond this distance, the device can be recessed (see figure 2), but not deeper than the height of the case (figure 3).

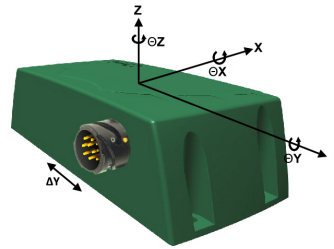

Operational tolerances of the beacon in relation with the reader :

$\Delta y_{\text{max}} = \pm 200\text{mm}$
($\pm 100\text{mm}$ recommended)

$\theta_x = \pm 10^\circ$
 $\theta_y = \pm 10^\circ$
 $\theta_z = \pm 10^\circ$

Metal grade:

The MOL81 1354 reader can be mounted directly on an aluminium plate (figure 4), $a > 10\text{cm}$.

It is possible to use a steel plate, but in this case it is needed to place an aluminium plate between the steel plate and the MOL81 1354 reader with $b > 5\text{cm}$ (figure 5), and $a > 10\text{cm}$.

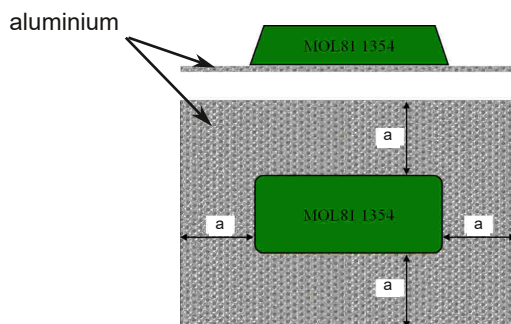

with aluminium

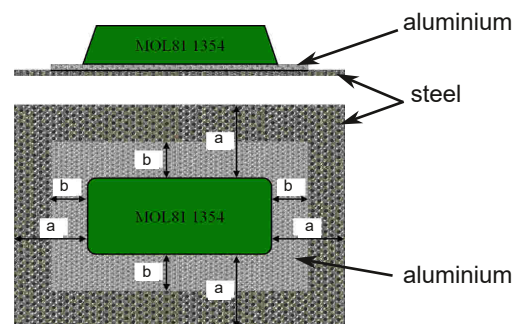

with steel : add an aluminium plate

Installation recommendation :

According to the steel grade, it should be necessary to consider the galvanic couple with the aluminium plate.

• Fixing:

Fixing 4 screws (not provided).

• Important:

Minimum distance between two readers: 2 m.

To avoid reading another beacon on adjacent track, the adjacent beacon has to be placed at a distance more than 1,9m

To keep a correct transmission zone length for one beacon, two beacons on the same way must be separated more than 2m

ADDITIONAL TECHNICAL INFORMATIVE

Radiation diagram

This diagram represents the typical identification zone between a MOL81 1354 reader and an OMR beacon.

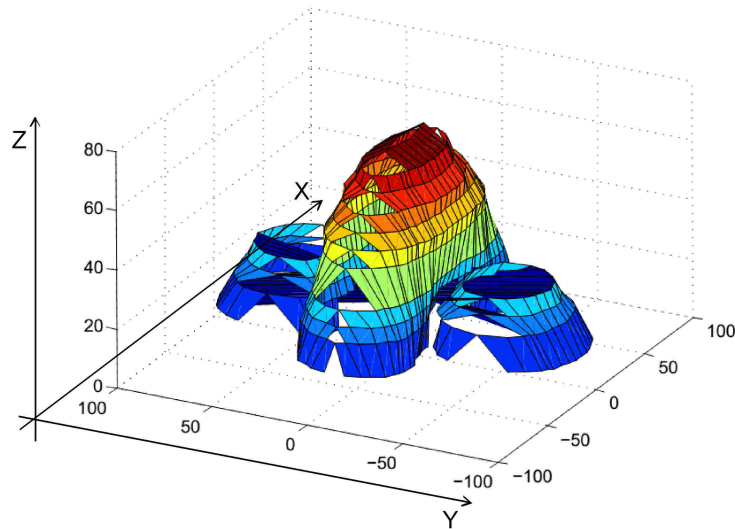

Frame Error Rate

The FER is given after measurements made in laboratory and with static conditions.

The quantity of data programmed in the beacon and send by the reader is 32 bits. The MOL81 1354 reader can not decode the data itself, therefore, for this measurement, the decoding is done by another microcontroller not inside the MOL81 1354 reader.

The FER varies with the distance d between the MOL81 1354 reader and the beacon. We can see below the shape of the FER versus the distance d .

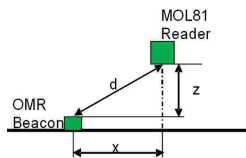

MOL81 1354 / OMR system
Frame Error Rate versus distance d

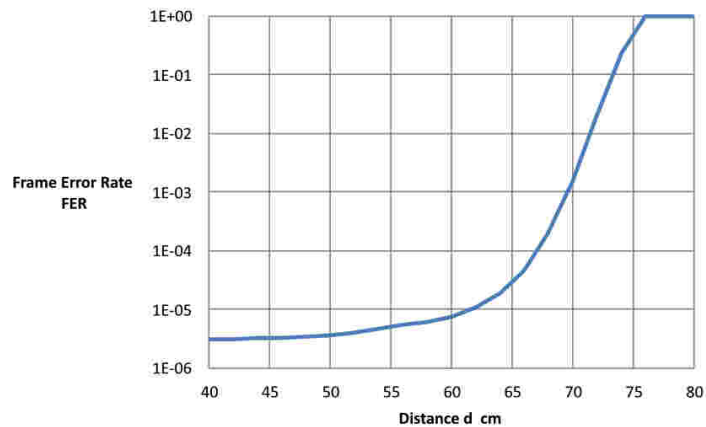

For information, the reader can send several frames to the calculator, during it is passing over the beacon.