

RAILWAYS Range

Monobloc Reader

[www.tagmaster.com](http://www.tagmaster.com)  
[contact@tagmaster.com](mailto:contact@tagmaster.com)

**MOL81 422**  
**1350 1355**

## DESCRIPTION

The MOL81 is a short range transceiver specially designed for railways applications. All in one device with integrated antenna, it will most often be used for on-board equipment which is placed on the outside under the mobile body, to read "on the fly" the contents of the OMR-type radio frequency identification beacons, placed along the track between the rails. Using a differential output, it will send the gathered data to a control device (programmable controller or embedded calculator ...) to ensure a localization function in real time or upon arriving at the terminal.

Dual frequency system, the MOL81 incorporate a 125 kHz transmitter for beacons remote power and a 6.78 MHz receiver for data coming from the beacon. The MOL81 has a self-test system that can be activated by a request through its serial link. It also provides two digital outputs, one of them ensuring that the 125kHz transmitter is correctly functioning, and the other indicates the "presence" of a beacon.

The MOL81 422 1350 1355 is compliant with EN 50155 and SNCF technical specification STM-E-001.

The MOL81 422 1350 1355 reader has a RS422 serial interface and is especially designed to read a beacon programmed with 11 bytes of data (see the user manual ref. 15886 for more information).



## FUNCTIONAL DATA

The OMR201 beacon can be read by a MOL81, as shown in the picture opposite.

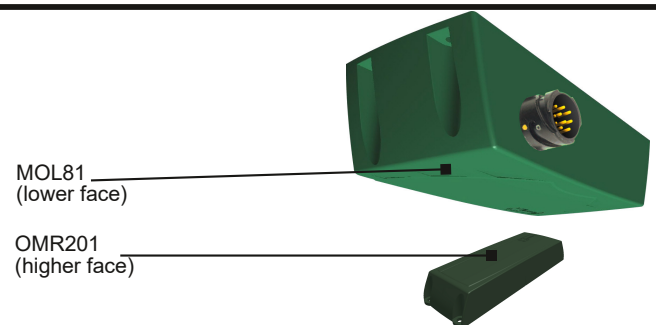

## DIMENSIONS and MARKING

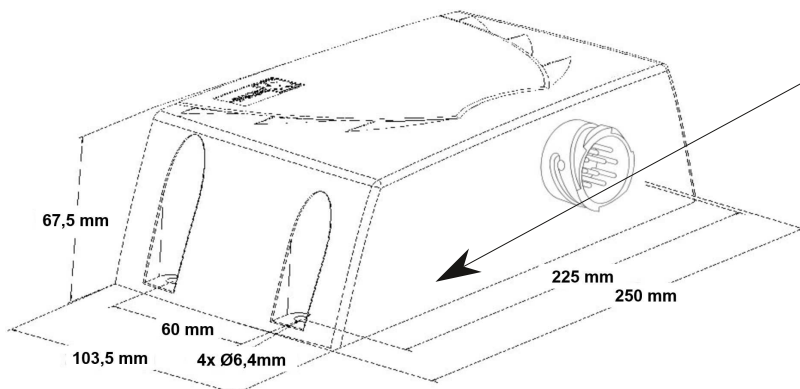

### Marking :

Part number identification :  
MOL81 422 1350 1355

Serial number identification :  
yywwxxxxx-nnn-v ss  
yy = year  
ww=week  
xxxxxx= manufacturing order  
nnn=serial number  
v=version index  
ss=software index

# TagMaster

LEARN FROM REALITY

**PRINCIPLE OF OPERATION**

The reader is designed to be powered with a SELV (Safety Extra Low Voltage) 24Vdc supply.

The transmitter at 125kHz allows to remotely power the beacon. It can be enabled and disabled with a command via the serial link. When activated, a permanent control of the emission at 125kHz is made by the reader. This information is sent directly to the "Pres125kHz" output, indicating the presence or absence of a correct 125kHz transmission. This information is also sent to the microcontroller which can return it via the serial link.

The receiver at 6.78MHz processes the identification signal sent by the beacon. After processing, the signal is sent to the microcontroller which is responsible for decoding this signal and sending it to the serial link. A "Pres Tag" output is activated as soon as the microcontroller decoded 2 correct identification frames.

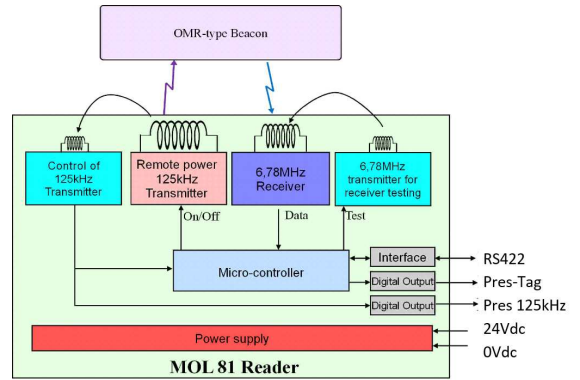

**TECHNICAL SPECIFICATIONS**

**Radiofrequency communication with OMR-type beacon**

	min	typ	max	unit
--	-----	-----	-----	------

Maximum length z for x=y=0 (1)			800	mm
Recommended range (1) Δz	100		600	mm
Transmission zone length (1) (2)	800			mm
Emission carrier frequency		125		kHz
Reception carrier frequency		6.78		MHz
Quantity of data reads by MOL81 1350		11		bytes

(1) : With metallic environment as indicated page 4

(2) : Position with respect to the beacon : maximum angular offset  $\theta_x$  : +/-10°;  $\theta_y$  : +/-10°;  $\theta_z$  : +/-10°, and maximum shift  $\Delta y$  = +/-100mm (see page 4) -  $\Delta z$  is the distance between the two opposite faces of the reader and the beacon

**Power supply**

DC power supply at the connector (ripple included) : Upwr	16,8	24	30	V
Consumption (125kHz transmitter active)		800	1500	mA
Consumption (125kHz transmitter inactive)		140	200	mA
Protection against reverse polarity	protected			-
Peak current at startup		2		A

**Digital output "PresTag"**

High level output voltage $V_{OH}$ @ $I_{OH}=10mA$	Upwr-2 Upwr-4			V
High impedance output leakage current			5	μA
Continuous output current $I_{OH}$			100	mA
Short circuit of the load	protected			-

**Digital output "Pres125kHz"**

High level output voltage $V_{OH}$ @ $I_{OH}=10mA$	15 10	21 15		V V
Low level output voltage $V_{OL}$			0,5	V
Continuous output current $I_{OH}$			40	mA
Short circuit of the load	protected			-

## TECHNICAL SPECIFICATIONS

### Insulation Groups

	min	typ	max	unit
N°1 : Power supply, Serial link, digital outputs				-
N°2 : Connector body, cable shield				-
Insulation voltage between each group	2			kVeff
Insulation resistance between each group @ 500Vdc	1			GΩ

### Others Electrical service conditions

Interruption of voltage supply EN 50155 -STM-E-01-IndB	Class S1	-
Power supply fluctuation around Un=24Vdc : EN 50155 -STM-E-01-IndB	0,6 Un to 1,4 Un : Criterion A	-
Voltage supply decrease-increase: STM-E-01-IndB	24Vdc to 0Vdc - 0Vdc to 24Vdc during 1minute	-
Supply change over : EN 50155 -STM-E-01-IndB	Class C1 & Class C2	-

### Environment

Operating temperature class Tx : EN 50155- STM-E-01-IndB (natural cooling)	-25	+70 <sup>(3)</sup>	°C
Storage temperature	-40	+85	°C
Electromagnetic (EMC) EN 50155 -STM-E-01-IndB	EN 50121-3-2 & EN 50121-4		-
Radiofrequency	EN 300 330		-
Human exposure	EN 50 364		-
Electrical safety	EN 60 950		-
Shock and vibrations: mounting on bogie (EN 50155 -STM-E-01-IndB) or sleeper	EN 61373 & EN 50125-3		-
Flammability grade : EN 50155 - STM-S-001	EN 45545-2 : R23 HL2		-
Ingress protection rating EN 50155 -STM-E-01-IndB	EN 60529 : IP67		-
Temperature cold test - dry heat test : EN 50155 -STM-E-01-IndB	EN 60068-2-1 & EN 60068-2-2		-
Temperature damp heat test : EN 50155 -STM-E-01-IndB- EN 60068-2-30	55°C insulation resistance>10MΩ		-
Humidity EN 50125-3 - EN 60068-2-78	95% insulation resistance>10MΩ		-
Altitude : EN 50155 -STM-E-01-IndB- EN 50125-1	1 200		m
Rapid temperature variations : EN 50155 -STM-E-01-IndB	EN 60068-2-14 : -40°C to +85°C		-
Low temperature storage test : EN 50155 -STM-E-01-IndB	EN 60068-2-1 : -40°C		-
Salt mist test : EN 50155 -STM-E-01-IndB	EN60068-2-11 : 500h		
Burn-in test : EN 50155 -STM-E-01-IndB (routine test)	96		h
RoHS European directive 2011/65/EU and REACH European directive 1907/2006	Compliance		-
Radio Equipment Directive (RED) 2014/53/EU	Compliance		-

(3) : including the possible effects of altitude and solar radiation of 1120W/m<sup>2</sup>

### Enclosure

Weight	2500	g
Enclosure material	PA6 (Polyamide 6)	-
Coating	Polyurethane	-
Recommended tightening torque (4 screws)	5	N.m

### RAMS features

MTBF according to IEC62380 railways	mobile installation : 627.000 fixed installation : 1.244.000	h
-------------------------------------	---	---

## CONNECTING

### Recommended cable:

- 6 or 8 wires:
  - Power supply : 2 wires
  - Output 'Pres125kHz' : 1 wire
  - Output 'PresTag' : 1 wire
  - RS 422 : 2 wires twisted pair, 120Ω line impedance (4)
- Overall shield; it must be in contact over 360° to the metallic cable connector housing
- Conductors connected by crimping, wire cross section : 0.5 to 1.5 mm<sup>2</sup> (depending of plug reference, see accessories)
- Outer diameter of cable: 8 to 12.5 mm (depending of plug reference, see accessories)
- Length: 1 200m for serial link and length for power link is according to wire cross section (typically 50 to 150m max)

### Connection:

Pin	MOL81 422 1350 1355
A	NC
B	RS 422 output DataTx-
C	Power supply : 24Vdc
D	RS 422 output DataTx+
E	RS 422 input DataRx+
F	Output 'PresTag'
G	NC
H	RS 422 input Data Rx-
J	Common : 0Vdc
K	Output : 'Pres125kHz'

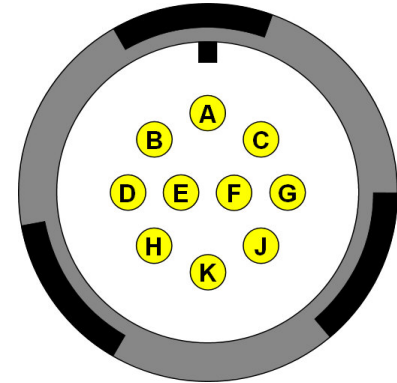

VGE1 type connector from Souriau  
Pin side view of the male receptacle  
or wiring side view of the female plug

(4) RS422 : line impedance matching done inside the device.

## MOUNTING SPECIFICATIONS

### Metallic environment for MOL 81 422 1350 1355 :

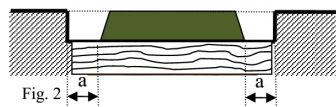
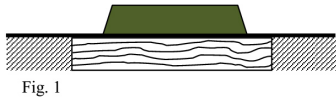

In order to guarantee correct range:

- The device must be mounted directly onto a metallic plate made of aluminium or non-magnetic stainless steel such as 316L (figure 1), which extends at least a=10cm beyond the base in both directions
- Beyond this distance, the device can be recessed (see figure 2), but not deeper than the height of

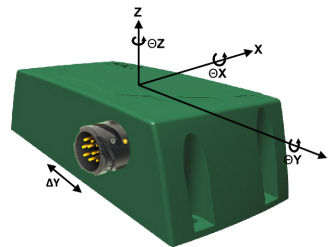

**Operational tolerances of the beacon in relation with the reader :**

- $\Delta y = +/-100\text{mm}$
- $\theta_x = +/-10^\circ$
- $\theta_y = +/-10^\circ$
- $\theta_z = +/-10^\circ$

### Fixing:

Fixing will be carried out by 4 screws (not provided), the MOL81 reader has 4 metallic inserts (stainless steel type A4 - 316L) for fixing.

### Important:

Minimum distance between two readers: 2 m.  
To avoid the reading of another beacon on adjacent way, the adjacent beacon has to be placed at a distance more than 2m.  
To keep a correct transmission zone length for one beacon, two beacons on the same way must be separated more than 2m.

## ACCESSORIES (to order separately)

- 10-pin female plug for Ø 8 to 12,5mm cable :  
FFM SOU VGE1/10P for straight version and FFM C SOU VGE1/10P for elbow 90° version

# TagMaster

LEARN FROM REALITY